

General Features

- It makes processing and cutting operations of PVC profiles.
- Precise measuring thanks to linear measurement system.
- Automatic greasing system.

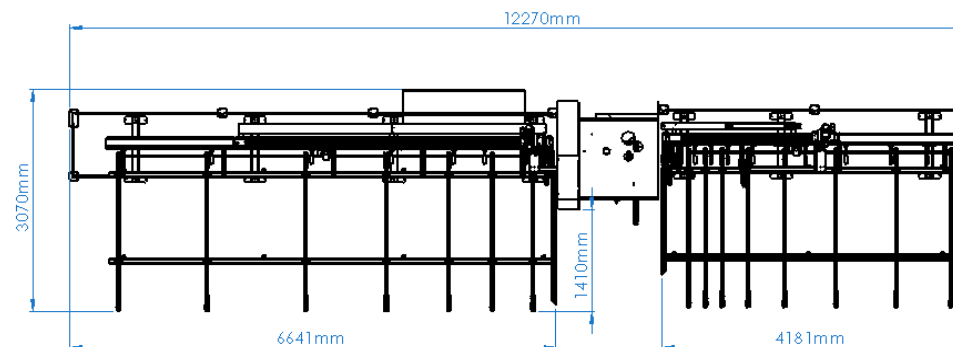

Technical Features

Profile Loading Unit

Entry Robot	11.5 kW 277,6 m/min
Conveyor	0,75 kW

Axis

Driller Angle	0,75 kW
Y Axis Servo Motor	0,4 kW
Z Axis Servo Motor	0,4 kW
Driller Motor	0,75kW 18000 d/d
Rapid Speed	30 / 60 /da

Profile Cutting Unit

Cutting Z	0,75 kW
Saw Motor	1,5 kW 2850 d/d
Saw Ratio	2 x Ø500 - 1 x Ø400

Profile Unloading Unit

Motor	1 kW 2000 d/d
Conveyor	0,75 kW

Machine Dimensions

Height	2190 mm
Width	3070 mm
Length	12270 mm

Profile Dimensions

Height	180 mm
Width	135 mm

Screen

17" lcd

Communication

Ethernet
USB

Software

KabanTransfer
Windows 7

Electricity

Voltage	400V (L1-L2-L3-N-PE) 50/60 Hz
Power	11 kW

Control Panel

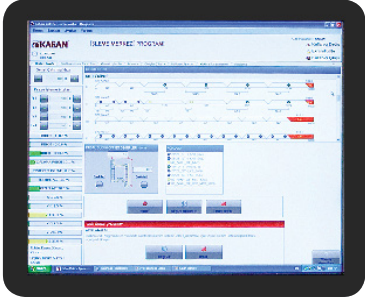

- User-friendly operating system compatible to all joinery and optimization programs.
- Minimum waste, maximum production algorithm.
- The wastes are optimized automatically in cutting list.
- Parameters are set easily.
- Different profiles and hardwares can be configured and optimized.
- Periodical maintenance reminder function.
- 17" LCD Screen.
- Usb input.

Profile Loading Unit

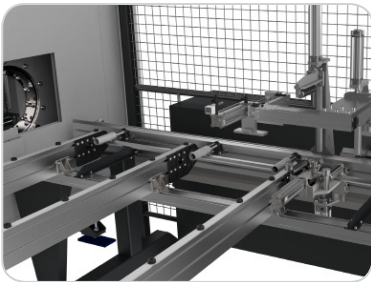

- Profile loading capacity: 9 profiles.
- Loading capacity can be increased optionally.
- Automatic profile recognition feature on profile conveyor and positioner.
- Profile Length: Minimum 850 mm – maximum 6.500 mm. (optionally eternal)
- Warning system to prevent wrong profile loading.

Profile Processing Unit

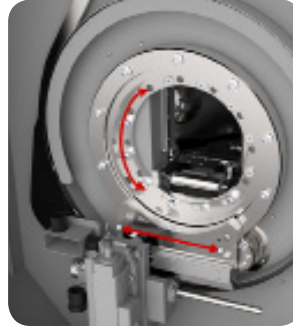

SB 3010

- The driller processes on horizontal axis and distance between 0-330 ° degrees.



SB 3020

- It processes with 7 drillers on horizontal axis and distance at 0°-45°-90°-135°-180°-225° and 270° degrees.

Profile Cutting Unit



SB 3010

- It cuts with 3 saws at 45° and 90° degrees.



SB 3020

- It cuts with rotating saw between 22,5°-157,5° degrees.

Profile Unloading Unit

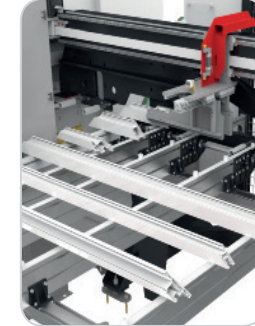

- Output robot conveys the cut profiles on conveyor automatically.
- The operator sticks the barcode on cut pieces to prepare for next operation.

Opsiyonlar



- PTR 200 Shelled Profile Trolley
It is designed to stock properly and carry the cut profiles easily.

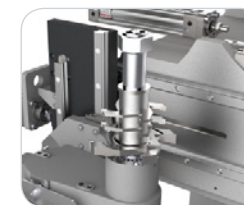

- OK 100 End Milling Unit
End milling of 2 profiles at the same time after the cutting unit.